

REDUCING UNION TEE

TRUT

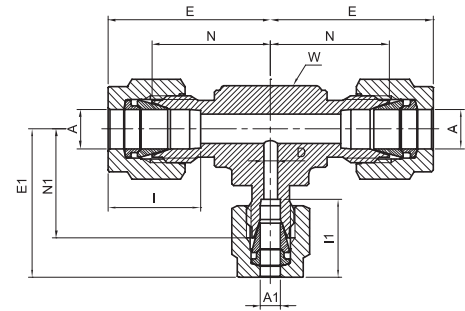

TUBE (INCH) TO TUBE (INCH)																				
Part Number	A Tube O.D.		A1 Tube O.D.		E		E1		I		I1		D		W Hex. flat		N		N1	
	in	mm	in	mm	in	mm	in	mm	in	mm	in	mm	in	mm	in	mm	in	mm	in	mm
TRUT - 6 - 6 - 4	3/8	9.52	1/4	6.35	1.20	30.5	1.14	29.0	0.66	16.9	0.60	15.3	0.19	4.8	5/8	15.9	0.91	23.1	0.85	21.6
TRUT - 8 - 8 - 4	1/2	12.70	1/4	6.35	1.42	36.1	1.25	31.8	0.90	22.9	0.60	15.3	0.19	4.8	13/16	20.6	1.02	25.9	0.96	24.4
TRUT - 8 - 8 - 6	1/2	12.70	3/8	9.52	1.42	36.1	1.31	33.3	0.90	22.9	0.66	16.9	0.28	7.1	13/16	20.6	1.02	25.9	1.02	25.9
TRUT - 10 - 10 - 6	5/8	15.88	3/8	9.52	1.53	38.9	1.42	36.1	0.96	24.4	0.66	16.9	0.28	7.1	15/16	23.8	1.13	28.7	1.13	28.7
TRUT - 12 - 12 - 6	3/4	19.05	3/8	9.52	1.57	39.9	1.46	37.1	0.96	24.5	0.66	16.9	0.28	7.1	1-1/16	27.0	1.17	29.7	1.17	29.7
TRUT - 12 - 12 - 8	3/4	19.05	1/2	12.70	1.57	39.9	1.57	39.9	0.96	24.5	0.90	22.9	0.41	10.4	1-1/16	27.0	1.17	29.7	1.17	29.7
TRUT - 16 - 16 - 6	1	25.4	3/8	9.52	1.93	49.0	1.65	41.9	1.23	31.2	0.66	16.9	0.28	7.1	1-3/8	34.9	1.45	36.8	1.36	34.5
TRUT - 16 - 16 - 8	1	25.4	1/2	12.70	1.93	49.0	1.76	44.7	1.23	31.2	0.90	22.9	0.41	10.4	1-3/8	34.9	1.45	36.8	1.36	34.5
TRUT - 16 - 16 - 12	1	25.4	3/4	19.05	1.93	49.0	1.76	44.7	1.23	31.2	0.96	24.5	0.62	15.8	1-3/8	34.9	1.45	36.8	1.36	34.5

HOW TO ORDER

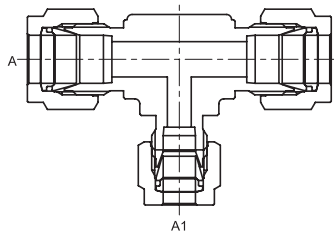
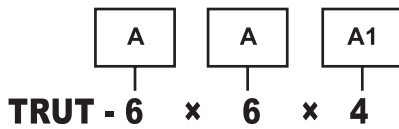

TUBE (INCH) TO TUBE (INCH)																				
Part Number	A Tube O.D.		A1 Tube O.D.		E		E1		I		I1		D		W Hex. flat		N		N1	
	in	mm	in	mm	in	mm	in	mm	in	mm	in	mm	in	mm	in	mm	in	mm	in	mm
TRUT - 6 - 4 - 6	3/8	9.52	1/4	6.35	1.20	30.5	1.14	29.0	0.66	16.9	0.60	15.3	0.19	4.8	5/8	15.9	0.91	23.1	0.85	21.6

"D" - Dimension is minimum opening - dimensions are for reference only, and are subject to change without notice.